

**VO Series Covert Smoke  
Detector Cameras**

With Digital Signal Processing (DSP), Auto-Trace white balance the VO Series covert smoke detector camera comes in with a built-in 3.7mm cone type lens and both Colour and Day & Night versions. This camera is designed to be disguised as an inconspicuous smoke detector. *Audio functionality is optional.*



**IC-VO38CT / IC-VO38CMT**

1/3" SONY CCD  
Picture Elements: NTSC - 510 x 492, PAL - 500 x 582  
380 TVL Horizontal Resolution

**IC-VO42CT / IC-VO42CMT**

1/3" SONY CCD  
Picture Elements: NTSC - 510 x 492, PAL - 500 x 582  
420 TVL Horizontal Resolution

**IC-VO54CT / IC-VO52CMT**

1/3" SONY CCD  
Picture Elements: NTSC - 768 x 494, PAL - 752 x 582  
540 TVL Horizontal Resolution

The covert smoke detector camera come with a 3.6mm standard lens. Optional 4.3, 6mm 8mm and 12mm lenses are available.\*

To assist you in choosing the correct lens option to suit your application please refer to the lens calculator on our web site at: [www.i-lax.ca](http://www.i-lax.ca) > On-line Tools > Lens Calculator.

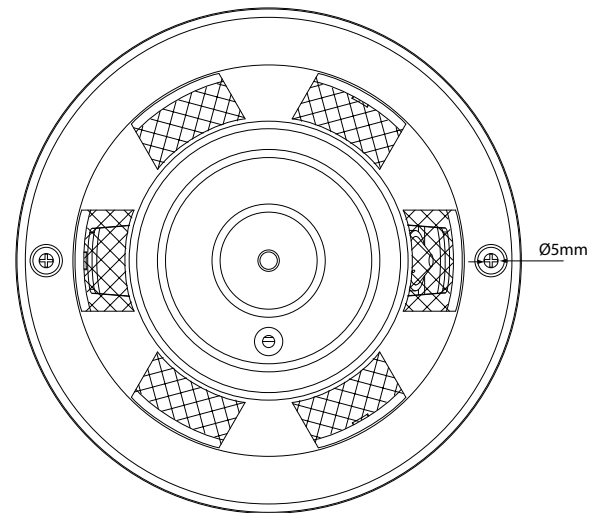
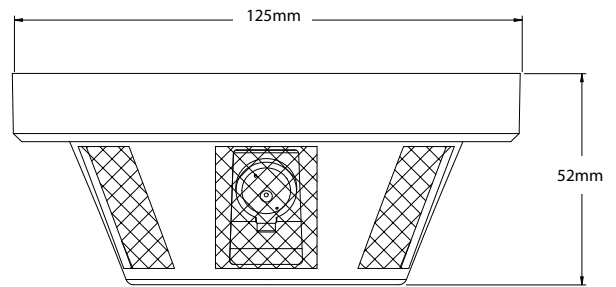
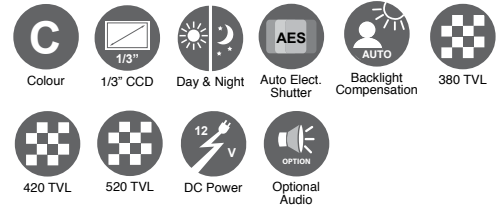

**ORDERING:**

**IC-VO38CT** Colour Covert Smoke Detector Camera, 380 TVL, 12v DC

**IC-VO42CT** Colour Covert Smoke Detector Camera, 420 TVL, 12v DC

**IC-VO54CT** Colour Covert Smoke Detector Camera, 540 TVL, 12v DC

**IC-VO38CMT** Night & Day Covert Smoke Detector Camera, 380 TVL, 12v DC

**IC-VO42CMT** Night & Day Covert Smoke Detector Camera, 420 TVL, 12v DC

**IC-VO54CMT** Night & Day Covert Smoke Detector Camera, 540 TVL, 12v DC

**NOTE:**

*Indicate if Audio Option is required.*  
Specify NTSC or PAL when ordering.

\* When ordering please specify the lens option you require. If unspecified, the standard 3.6mm lens will be supplied

Model	IC-VO38CT	IC-VO38CMT	IC-VO42CT	IC-VO42CMT	IC-VO54CT	IC-VO54CMT
<b>Operational</b>						
Image Sensor	1/3" SONY Super HAD CCD Technology					
Number of Effective Pixels	<u>Effective:</u> NTSC: 510 x 492 / PAL: 500 x 582			NTSC: 768 x 494 / PAL: 752 x 582		
	<u>Total:</u> NTSC: 537 x505 / PAL: 537 x597			NTSC: 811 x 508/ PAL: 795 x 596		
Auto Gain Control (AGC)	Auto (max. 34dB)					
Exposure Control	AES					
Back Light Compensation (BLC)	Auto detect, histogram and 225 areas windows weighted					
Electronic Shutter	1/50 (60) to 1/100,000 second					
Gamma Correction	0.45					
White Balance	Auto tracking 2500K to 9500K					
Video Output	1Vp-p. 75 Ω BNC Connector					
Scanning Mode	2:1 interlace scan					
Scanning Line	NTSC: 525 lines / PAL: 625 lines					
Hor. scanning frequency	NTSC: 15.734K Hz / PAL: 15.625K Hz					
Ver. scanning frequency	NTSC: 59.94K Hz / PAL: 50K Hz					
Acceptable IR wavelength	N/A	100 to 1100nm	N/A	100 to 1100nm	N/A	100 to 1100nm
Aperture Correction	Horizontal and Vertical 2H enhancer					
System	NTSC / PAL					
Lens Mount	12Ø Board Lens Mount – Screw Type					
Built-in Lens	Cone type pin hole lens 3.7mm (f2.0)					
Horizontal Resolution	380TVL		420TVL		540TVL	
Sensitivity (30IRE, SAGC)	Color	0.1 lx @ F1.2			0.5 lx @ F1.2	
	B/W	0.03 lx @ F1.2		0.03 lx @ F1.2		0.08 lx @ F1.2
<b>Electrical</b>						
Input Voltage Options	12v DC					
Power Consumption	12v - 120mA 270mA when IR illuminator on		12v - 150mA 290mA when IR illuminator on			
Synchronization	12v DC – Internal					
<b>General</b>						
Operating Temperature	10°C to 50°C (14°F to 122°F)					
Operating Humidity	20% ~ 80% (non compensating)					
Storage Temperature	-20°C to 70°C (-4°F to 158°F)					
Storage Humidity	20% ~ 95% (non compensating)					
Construction	Plastic Housing / Beige Finish					
Weight / Size	0.3Kg (0.66 Lbs.)					

## VO Series Covert Smoke Detector Cameras

### REGULATORY:

CE (EN5513, EN50130-4)

EU: 73/23/EEC LVD

RoHS Compliant

